

ROTEX

SERVICE INSTRUCTIONS

FOR MODELS DRS SERIES

DRSB TO DRSM

PNEUMATIC ACTUATOR



REVISION: "0"
DATE: OCT 2010

SECTION 1 - INTRODUCTION

1.1 GENERAL SERVICE INFORMATION

1.1.1 This service procedure is offered as a guide to enable general maintenance to be performed on Rotex DRS Double Acting and Spring Return Series Pneumatic Actuators.

1.1.2 Normal recommended service interval for this actuator series is five years.

NOTE: Storage time is counted as part of the service interval.

1.1.3 This procedure is applicable with the understanding that all pneumatic pressure has been removed from the actuator.

1.1.4 Remove all piping and mounted accessories that will interfere with the module(s) that are to be worked on.

1.1.5 This procedure should only be implemented by a technically competent technician who should take care to observe good workmanship practices.

1.1.6 Numbers in parentheses, () indicate the bubble number (reference number) used on the Rotex Assembly Drawing and Actuator Parts List.

1.1.7 When removing seals from seal grooves, use a commercial seal removing tool or a small screwdriver with sharp corners rounded off.

1.1.8 Use a non-hardening thread sealant on all pipe threads.

CAUTION: Apply the thread sealant per the manufacture's instructions.

1.1.9 All parts should be thoroughly inspected for excessive wear, stress cracking and pitting. Attention should be directed to threads, sealing surfaces and areas that will be subjected to sliding and rotating motion.

CAUTION: Actuator parts that reflect any of the above listed characteristics should be replaced with new parts.

1.1.9 Rotex recommends that disassembly of the actuator modules should be done in a clean area on a workbench.

1.2 DEFINITIONS

WARNING: If not observed, user incurs a high risk of severe damage to actuator and/or fatal injury to personnel.

CAUTION: If not observed, user may incur damage to actuator and/or injury to personnel.

NOTE: Advisory and information comments provided to assist maintenance personnel to carry out maintenance procedures.

1.3 GENERAL SAFETY INFORMATION

Products supplied by Rotex, in its "as shipped" condition, are intrinsically safe if the instructions contained within this Service Instruction are strictly adhered to and executed by well-trained, equipped, prepared and competent personnel.

WARNING: For the protection of personnel working on Rotex actuators, this procedure should be reviewed and implemented for safe disassembly and reassembly. Close attention should be noted to the WARNINGS, CAUTIONS and NOTES contained in this procedure.

1.4 ROTEX REFERENCE MATERIALS

- 1.4.1 Cross sectional assembly drawing for Double acting Actuator.
- 1.4.2 Cross sectional assembly drawing for spring return Pneumatic Actuator.

1.5 SERVICE SUPPORT ITEMS

- 1.5.1 Seal kit.
- 1.5.2 Bearings.

SECTION 2 - ACTUATOR ASSEMBLY

2.1 GENERAL DISASSEMBLY

WARNING: It is possible, that the actuator may contain a dangerous gas and/or liquids. Ensure that all proper measures have been taken to prevent exposure or release of these types of contaminants before commencing any work.

- 2.1.1 Actuator assembly is written to either completely disassemble the entire actuator or can be used to disassemble individual Modules as needed (Pneumatic cylinder).
- 2.1.2 When the spring retainer assembly is to be removed it should be removed from the central block (15) drive assembly prior to the Pneumatic cylinder assembly removal or disassembly.
- 2.1.3 To ensure correct reassembly, mark or tag mating surfaces.
- 2.1.4 Actuator central block (15) base should be rigidly mounted before disassembly of any component.

2.2 DOUBLE ACTING ACTUATOR ASSEMBLY

WARNING: If not already removed disconnect all operating pressure from actuator power cylinders for disassembly.

WARNING: The spring cartridge must be checked to verify that the spring(s) are in their extended position before the spring retainer assembly is disassembled from the central block (15) drive assembly. This can be checked by verifying stroke adjustment screws are not in tension.

- 2.2.1 Fix central block (15) on rigid fixture, clean it properly put some grease and insert bearing (24) as shown.
- 2.2.2 Assemble carrier (6) with the yoke (18) with the help of yoke pin (5) and fix it with the help of grub screw (53) provided in the carrier. Now assemble the yoke pin unit with the help of needle bearing (25) and cage (26). Put external circlip on both side of the pin (50).
- 2.2.3 Insert oring (42) in yoke (18) and insert the entire yoke & carrier assembly in the central block (15). Place it into bottom bearing (24). Put oring (39) on the guide rod (9) & insert it in the central block (15) from the side. Make sure that the guide rod should pass through the carrier assembly.
- 2.2.4 Now put oring (43) in the yoke insert (8) and fix it on the yoke (18) with the help of hex socket head bolts (32). Now fit the top bearing (24) on the yoke.
- 2.2.5 Now assemble the cylinder unit separately. Put the bearing bush (4) in the front cover (21) with the seals (3), (41) & external circlip (49). Fix the tie rods (10) on the front cover (20). Now put oring (36) and fix the

front cover unit with the tube (1). Before fixing the tube, make sure that the tube & front cover are cleaned properly.

- 2.2.6 Put the seal (40) and piston strip (52) on the piston (21). Now put the guide bushes (17) and seals (46), (37) in the piston. After fitting the bushes fix it with external circlip (48). Lubricate the inside of tube and the tie rods. Now push the piston into the tube with the tie rods in position.
- 2.2.7 In order to fit the piston rod, push the piston (21) towards the front cover (20). Now enter the piston rod (2) from outer side of the front cover (20) and fix it to the piston (21) with the help of bolt (13).
- 2.2.8 Now put the oring (36) on rear cover (22). Put oring (38) on the tie rods (10) and fix the rear cover on the tube (1) with the help of spring washer (45) and hex Nut (10).
- 2.2.9 In order to connect the cylinder assembly with the central block (15), we need to move the carrier assembly towards the extreme position. Now with the help of connecting nut (7) fix the piston rod to the carrier.
- 2.2.10 After tightening the connecting nut (7), fix the cylinder assembly with the help of hex. socket head bolts (31).
- 2.2.11 For **Double acting**, put the oring (41) in rear cover (27) and fit on the central block with the help of hex. socket head bolts (31).
- 2.2.12 Now put the oring (12) on the central block cover (16) and fix it the help of hex. socket head bolts (34).

2.3 SINGLE ACTING ACTUATOR ASSEMBLY

- 2.3.1 Follow the same procedure of double acting assembly. Remove rear cover (27).
- 2.3.2 Move the carrier assembly towards the extreme position of spring side. In this two connecting nuts (7) are used in the carrier (6).
- 2.3.3 Now align the spring cartridge assembly with the central block and fit the connecting rod (57) with the carrier with help of connecting nut (7). After this fix the spring cartridge with the help of hex. socket head bolts (31).
- 2.3.4 Now put the oring (12) on the central block cover (16) and fix it the help of hex. socket head bolts (34).

2.4 DO'S or DON'TS

- 2.4.1 Don't disassemble the actuator in closed or congested area because this may result damage to actuator and/or injury to personal.
- 2.4.2 Mark or tag the components while disassembling and mark mating surfaces.
- 2.4.3 Don't use hammer with metallic end for installation.
- 2.4.4 Use proper tools to disassemble the actuator.

Double Acting

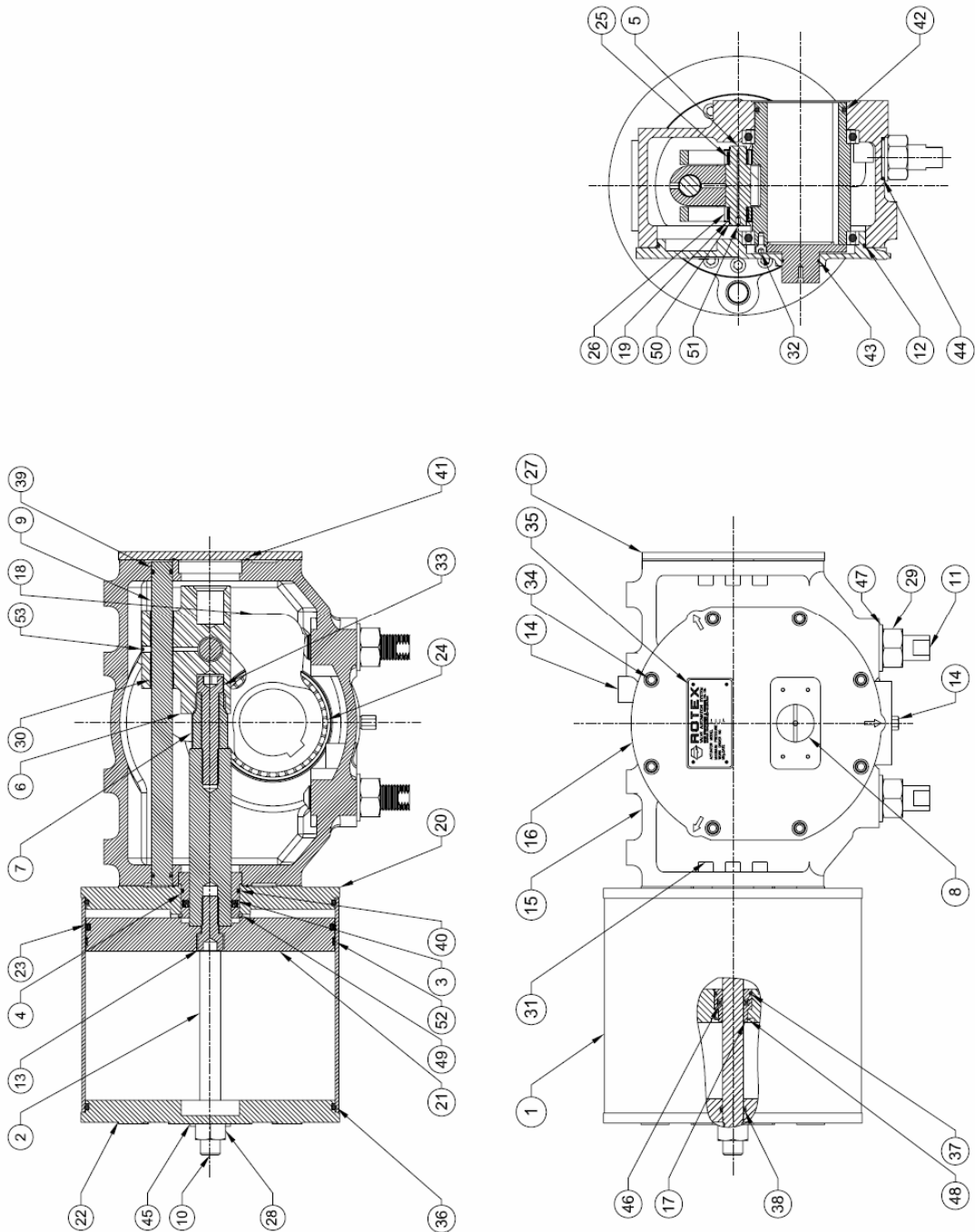

IOM - ROTEX DRS Series Heavy Duty ACTUATORS, PNEUMATIC SCOTCH YOKE TYPE

DIRECT ACTING AND SPRING RETURN

ROTEX DRS IOM Iss April 2010

All rights reserved

53	GRUB SCREW	1	-
52	TEFLON STRIP	1	-
51	LUBRICATION NIPPLE	1	-
50	EXTERNAL CIRCLIP	2	-
49	EXTERNAL CIRCLIP	1	-
48	EXTERNAL CIRCLIP	2	-
47	WASHER	2	-
46	QUAD SEAL FOR GUIDE BUSHING	2	NBR
45	SPRING WASHER	2	-
44	ORING	2	NBR
43	ORING	1	NBR
42	ORING	1	NBR
41	ORING	2	NBR
40	ORING	1	NBR
39	ORING	2	NBR
38	ORING	2	NBR
37	ORING	2	NBR
36	ORING	2	NBR
35	NAME PLATE	1	ALUMINIUM
34	HEX SOCKET HEAD SCREW (HIGH TENSILE)	8	-
33	HEX SOCKET HEAD SCREW (HIGH TENSILE)	1	-
32	HEX SOCKET HEAD SCREW (HIGH TENSILE)	4	-
31	HEX HEAD SCREW (HIGH TENSILE)	12	-
30	BUSHING	2	PHOSPHOR BRONZE
29	HEX NUT	2	-
28	HEX NUT	2	-
27	REAR CAP	1	DUCTILE IRON
26	CAGE FOR NEEDLE BEARING	2	20MnCr5
25	NEEDLE BEARING	2	-
24	BALL BEARING	2	-
23	QUAD SEAL FOR PISTON	1	NBR
22	CYL COVER REAR END	1	DUCTILE IRON
21	PISTON	1	DUCTILE IRON
20	CYL COVER FRONT END	1	DUCTILE IRON
19	WASHER FOR BEARING	2	SS304
18	YOKE	1	DUCTILE IRON
17	GUIDE BUSHING	2	PHOSPHOR BRONZE
16	CENTRAL BLOCK COVER	1	DUCTILE IRON
15	CENTRAL BLOCK	1	DUCTILE IRON
14	CHECK VALVE	1	-
13	HEX SOCKET HEAD SCREW (HIGH TENSILE)	1	-
12	ORING FOR TOP COVER	1	NBR
11	TRAVEL ADJ. BOLT	2	EN8
10	TIE ROD FOR CYLINDER	2	EN8
9	GUIDE ROD	1	EN8
8	YOKE INSERT	1	DUCTILE IRON
7	CONNECTING NUT	1	EN19
6	CARRIER	1	DUCTILE IRON
5	YOKE PIN	1	20MnSr5
4	BEARING BUSHING	1	PHOSPHOR BRONZE
3	LIP SEAL FOR PISTON ROD	1	NBR
2	PISTON ROD	1	EN8
1	CYLINDER	1	M.S
SR. NO.	DESCRIPTION	QTY.	MATERIAL

Spring Return

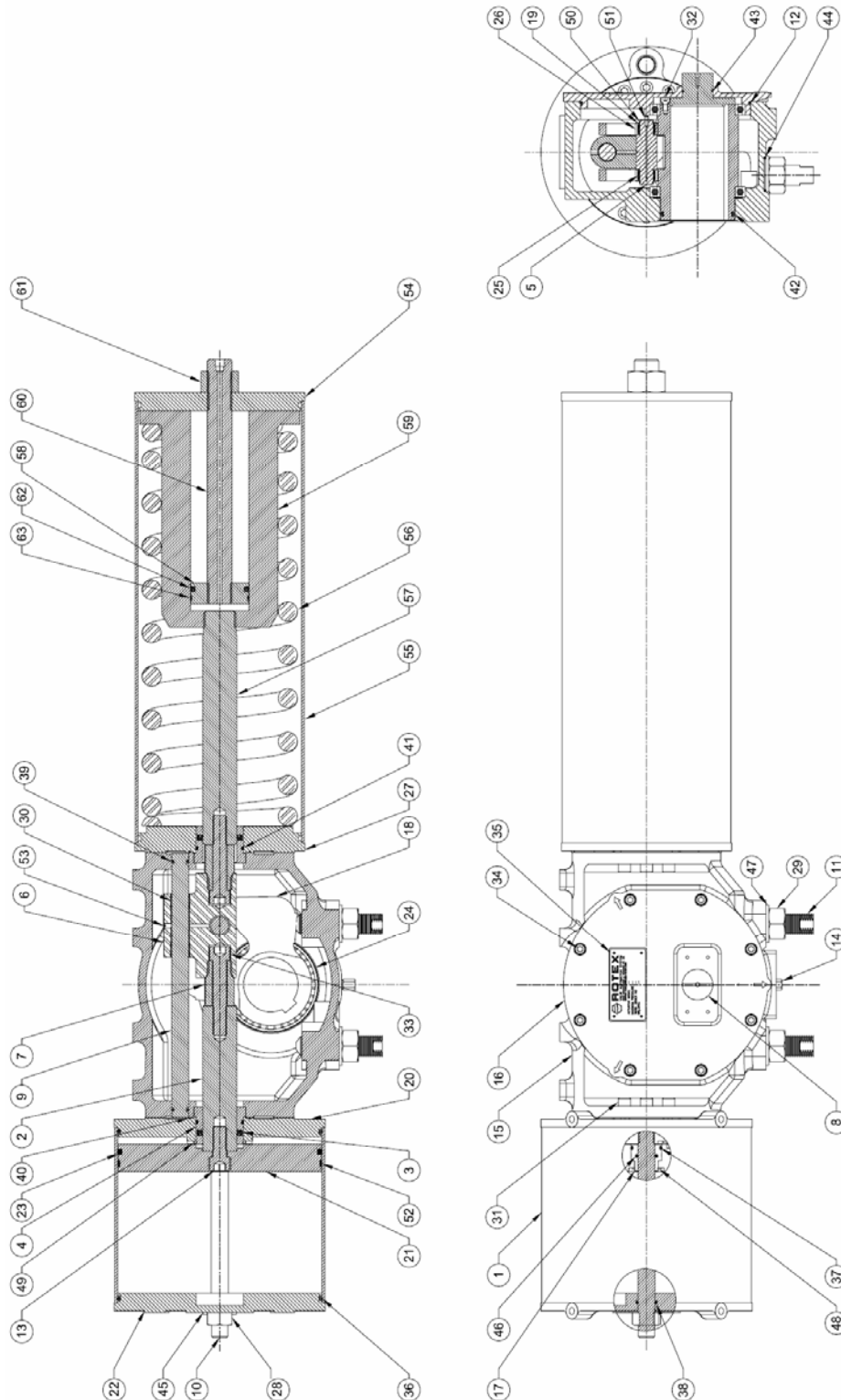



IOM - ROTEX DRS Series Heavy Duty ACTUATORS, PNEUMATIC SCOTCH YOKE TYPE

DIRECT ACTING AND SPRING RETURN

ROTEX DRS IOM Iss April 2010

All rights reserved

SR. NO.	DESCRIPTION	QTY.	MATERIAL
63	TEFLON STRIP	1	-
62	LIP SEAL	1	-
61	HEX NUT	1	-
60	PISTON ROD FOR HYDRAULIC MANUAL OVERRIDE	1	CARBON STEEL
59	SPRING RETAINER	1	CARBON STEEL
58	PISTON FOR HYDRAULIC MANUAL OVERRIDE	1	CARBON STEEL
57	CONNECTING ROD	1	STAINLESS STEEL
56	SPRING	1	EN 47
55	SPRING TUBE	1	M.S.
54	SPRING COVER REAR END	1	DUCTILE IRON
53	GRUB SCREW	1	-
52	TEFLON STRIP	1	-
51	LUBRICATION NIPPLE	1	-
50	EXTERNAL CIRCLIP	2	-
49	EXTERNAL CIRCLIP	2	-
48	EXTERNAL CIRCLIP	2	-
47	WASHER	2	-
46	QUAD SEAL FOR GUIDE BUSH	2	NBR
45	SPRING WASHER	2	-
44	ORING	2	NBR
43	ORING	1	NBR
42	ORING	1	NBR
41	ORING	2	NBR
40	ORING	2	NBR
39	ORING	2	NBR
38	ORING	2	NBR
37	ORING	2	NBR
36	ORING	2	NBR
35	NAME PLATE	1	ALUMINIUM
34	HEX SOCKET HEAD SCREW (HIGH TENSILE)	8	-
33	HEX SOCKET HEAD SCREW (HIGH TENSILE)	2	-
32	HEX SOCKET HEAD SCREW (HIGH TENSILE)	4	-
31	HEX HEAD SCREW (HIGH TENSILE)	12	-
30	BUSHING	2	PHOSPHOR BRONZE
29	HEX NUT	2	-
28	HEX NUT	2	-
27	SPRING COVER FRONT END	1	DUCTILE IRON
26	CAGE FOR NEEDLE BEARING	2	20MnCr5
25	NEEDLE BEARING	2	-
24	BALL BEARING	2	-
23	QUAD SEAL FOR PISTON	1	NBR
22	CYL COVER REAR END	1	DUCTILE IRON
21	PISTON	1	DUCTILE IRON
20	CYL COVER FRONT END	1	DUCTILE IRON
19	WASHER FOR BEARING	2	SS304
18	YOKE	1	DUCTILE IRON
17	GUIDE BUSHING	2	PHOSPHOR BRONZE
16	CENTRAL BLOCK COVER	1	DUCTILE IRON
15	CENTRAL BLOCK	1	DUCTILE IRON
14	CHECK VALVE	1	-
13	HEX SOCKET HEAD SCREW (HIGH TENSILE)	1	-
12	ORING FOR TOP COVER	1	NBR
11	TRAVEL ADJ. BOLT	2	EN8
10	TIE ROD FOR CYLINDER	2	EN8
9	GUIDE ROD	1	EN8
8	YOKE INSERT	1	DUCTILE IRON
7	CONNECTING NUT	2	EN19
6	CARRIER	1	DUCTILE IRON
5	YOKE PIN	1	20MnSr5
4	BEARING BUSHING	2	PHOSPHOR BRONZE
3	LIP SEAL FOR PISTON ROD	2	NBR
2	PISTON ROD	1	EN8
1	CYLINDER	1	M.S